



Principal dining table

Design Bodil Kjær

Year 1961



Bodil Kjær

She has been featured in The New York Times and Wall Street Journal Magazine. She designed a desk for MIT which was dubbed 'The most beautiful desk in the world' and eventually immortalized in three early James Bond movies. Danish architect, designer and professor Bodil Kjær (born 1932) is the female trail-blazer of Danish midcentury design, who although tutored by modernist master Finn Juhl, in her own words "... never had much interest in following in the footsteps of the Danish rat pack". Kjær looked to America, inspired by Charles and Ray Eames, and indeed many of her most notable designs stems from her time in the U.S., where she briefly worked at Paul McCobb, before moving to Boston to further her career in corporate interior architecture.



One of the last living mid-century Scandinavian design pioneers and a female pioneer in the field of architecture in her time, Bodil Kjær, conceived her Principal series in 1961 as part of an architectural exploration of interior solutions for modern living, called Elements of Architecture. Comprising a dining table and an upholstered dining chair, the Principal series epitomises Kjær’s forward-thinking cosmopolitan outlook and modernistic design language that slips fluidly into contemporary interior.

The solid wood dining table boasts a clarified form, repeating a simple angle throughout table legs and ends of the table top, while the dining chair with its circular seat and gently rounded backrest, beautifully upholstered, adds a softness to the clear, unfussed geometry, an invitation to linger.

PRODUCT DATA

Design	Bodil Kjær. 1961
Product type	Dining table
Environment	Indoor
Materials	Frame in solid oak or walnut with clear lacquer, table top in oak or walnut veneer with clear lacquer, plastic gliders

DELIVERY

Lead time	15 to 16 weeks
Packing	Flat packed

CODES

201714	Principal dining table 240cm, natural oak
201739	Principal dining table 240cm, white stained oak
201740	Principal dining table 240cm, smoke stained oak
201705	Principal dining table 240cm, walnut
202247	Principal dining table 260cm, natural oak
202178	Principal dining table 260cm, white stained oak
202246	Principal dining table 260cm, smoke stained oak
202185	Principal dining table 260cm, walnut
202249	Principal dining table 280cm, natural oak
202141	Principal dining table 280cm, white stained oak
202248	Principal dining table 280cm, smoke stained oak
202184	Principal dining table 280cm, walnut

Finishes

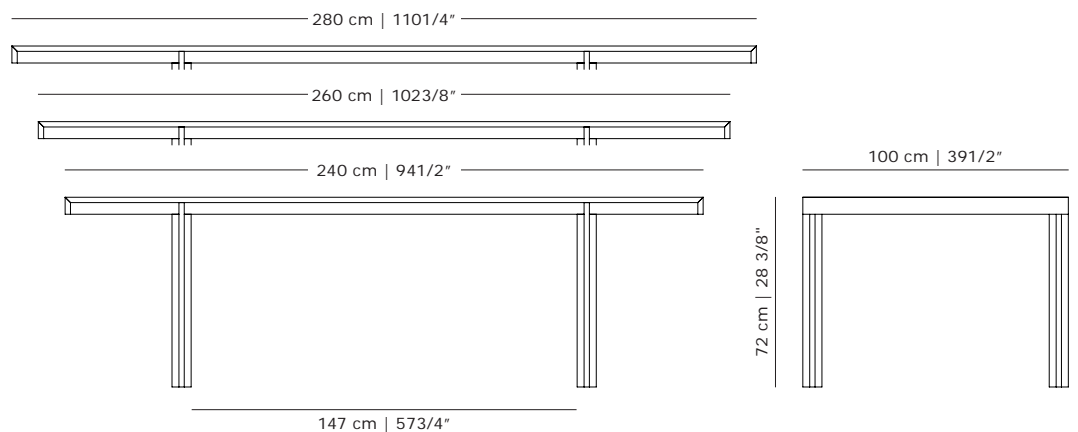
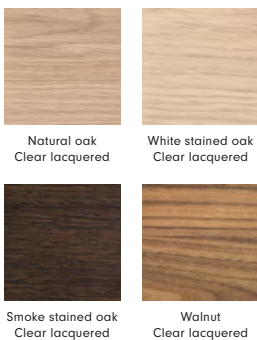



Founded on rebellious curiosity and a passion for the unique, Karakter is a bit out of the ordinary. Rooted in the proud Danish design tradition, but always maintaining an international outlook, Karakter presents a striking portfolio of furniture, lighting and objects from designers who have already written the history of design to those who are aspiring to write the future. All designers collaborating with Karakter are curated for their ideas and creativity and shared by all of them is an inspiring level of curiosity and an uncompromising take on their work. Boasting both the relevant and honest, the beautiful, the playful and the expressive, all designs have a clear, undeniable character. Ready to spark curiosity and start conversations.

Head Office

Karakter
 Gammel Lundtoftevej 1C
 2800 Kongens Lyngby
 Denmark

T +45 38 41 41 31
 @karaktercopenhagen
 info@karakter-copenhagen.com